



For Technical Support visit us at www.sunsetter.com/ownerscorner
or Call Toll Free 800-670-7071 • Fax 877-224-4944

VISTA, Motorized and PRO Fabric Replacement Instructions

*** Helper Needed ***

Tools Needed: Phillips Screwdriver

WARNING: FAILURE TO WEAR SAFETY GLASSES OR TO FOLLOW THE INSTRUCTIONS BELOW CAN RESULT IN PERSONAL INJURY!

This Section is for All VISTA, Motorized and PRO Awnings, except Motorized PRO Awnings with the Motor Mounted on the LEFT Side ONLY, as You Face the House. For Motorized PRO Awnings with the Motor Mounted on the LEFT Side, as You Face the House, Please go to Step 14 in the Next Section.

1. Open the Awning to the fully extended position.

2. **Motorized Models:** Place the Remote Transmitter Button in the neutral position (press the **MY** button) and unplug the power cord from the outlet. For Awnings without the Remote Option, set the Wall Switch to the Neutral Position and unplug the power cord from the outlet.

Note: For Awnings that have a SunSetter Aluminum Hood installed, remove the Hood End Plate on the opposite side of the Motor or Gear assembly. See Figure 1.

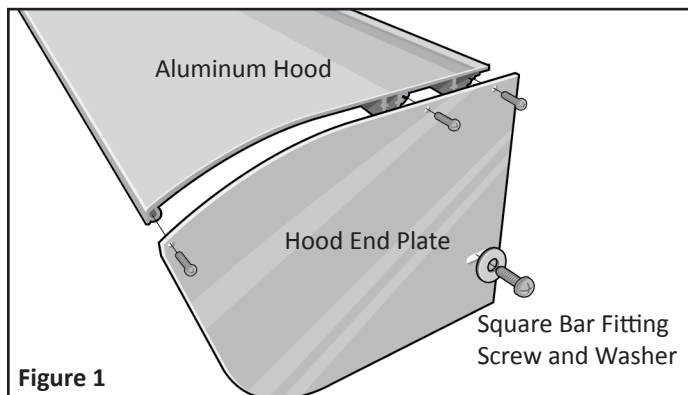

3. Using the Manual Crank Wand, continue to unroll the Fabric until you expose the Fabric Slot in the Roller Bar. See Figure 2.

4. **ON THE OPPOSITE SIDE OF THE MOTOR OR GEAR ASSEMBLY,** remove the two (three screws for the PRO Front Bar) Phillips screws from the End Plate of the Front Bar. See Figure 3.

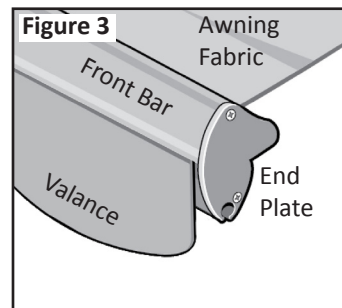
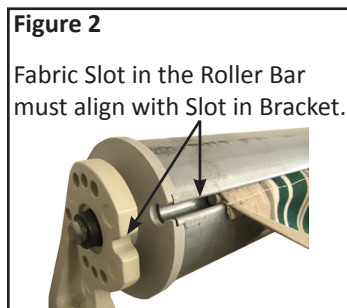

5. **NOTE THE ORIENTATION OF THE FABRIC:**

Darker stripes are toward the Front Bar (Laminated striped vinyl Fabrics only) and hemmed (folded) edges on each side of the Fabric are always facing down (for all Fabrics).

6. With your helper, pull the old Fabric out of the **Roller Bar** and **Front Bar** slots AT THE SAME TIME. If replacing the Valance as well, remove the old Valance from its slot in the Front Bar.

7. Remove the new Fabric from its packaging. Orient it the same way as explained in Step 5.

Note: The Fabric must be inserted into the Roller Bar and Front Bar Slots at the same time. You might have to do so in small steps, alternating from one bar to the other.

CAUTION: TO PREVENT DAMAGE TO THE FABRIC, HAVE YOUR HELPER DIRECT THE FABRIC INTO THE SLOT, WHILE YOU SLOWLY PULL THE FABRIC THROUGH THE SLOT, TO THE OTHER END.

8. With your helper, carefully insert the Fabric into the slots on the Roller Bar and Front Bar. You might have to hold the Front Bar steady while doing so. Repeat for the Valance.

9. Center the Fabric on the Roller Bar and the Front Bar.

10. While keeping the Fabric reasonably stretched on the Roller Bar, use the Manual Crank Wand to slowly roll the Fabric onto the Roller Bar, until both arms start to close. **The Fabric should roll OVER THE TOP and onto the Roller Bar.**

11. Reinstall the End Plate on the Front Bar with the two (see Figure 3) Phillips screws (three screws for the PRO model, see Figure 6). For either model, reinstall the Hood End Plate if removed.

12. **Motorized Models:** Check that the Remote Transmitter or Wall Switch is still in the neutral position (press the MY button), then plug the power cord back into the outlet.

13. Test the Awning for proper operation.

Note: If you need to adjust motor stops, refer to the enclosed instructions on how to reset the motor stops. See Page 3 for “How to Identify Your Specific Type of Motor for Resetting Motor Stops” before proceeding to Reset Instructions on Pages 4 through 6.

For PRO Awnings with Motors Installed on the LEFT Side as You Face the House.

14. Open the Awning to the fully extended position.

15. Place the Remote Transmitter Button in the neutral/stop position (press the MY button) and unplug the power cord from the outlet.

Note: For Awnings that have a SunSetter Aluminum Hood installed, on the opposite side of the Motor or Gear assembly, remove the Hood End Plate. See Figure 1.

16. Using the Manual Crank Wand, continue to unroll the Fabric until you expose the Fabric Slot in the Roller Bar. See Figure 4.

17. Insert the Manual Crank Wand into the Crank Loop on the front bar. See Figure 5.

18. Turn the Crank counter-clockwise to unroll the Weather Breaker Panel until the Panel is fully extended.

19. **ON THE OPPOSITE SIDE OF THE MOTOR,** remove the three Phillips screws from the End Plate of the Front Bar. See Figure 6.

Note: Use care so that loose components of the Crank Assembly are not misplaced. See Figure 6.

20. **NOTE THE ORIENTATION OF THE FABRIC:** Darker stripes are toward the Front Bar (Laminated striped vinyl Fabrics only) and hemmed (folded) edges on each side of the Fabric are always facing down (for all Fabrics).

21. With your helper, pull the old Fabric out of the **Roller Bar and Front Bar slots AT THE SAME TIME.** If replacing the Valance as well, remove the old Valance from its slot in the Front Bar.

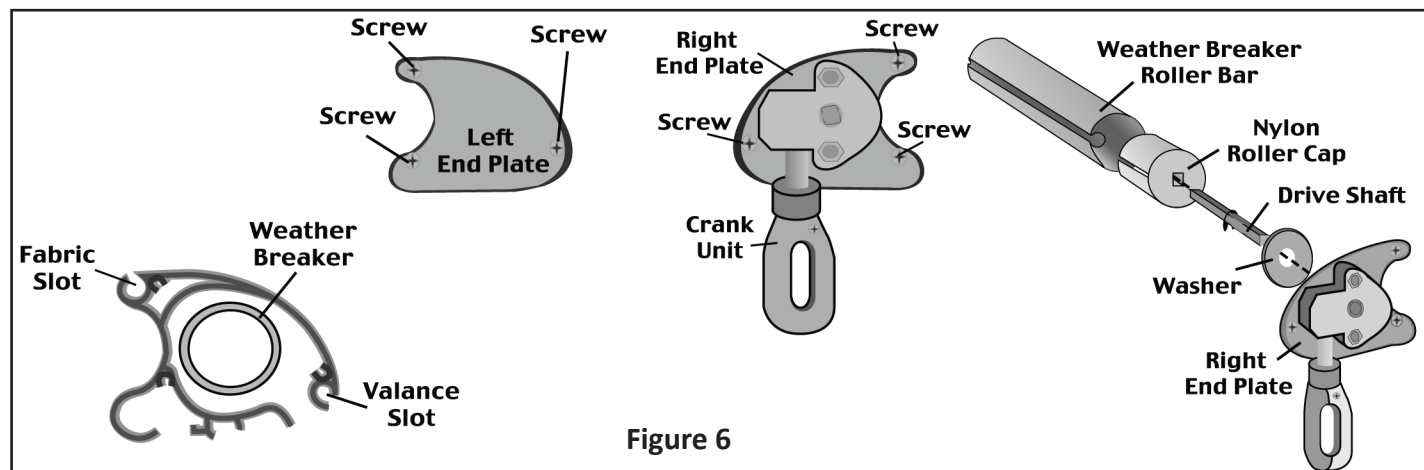
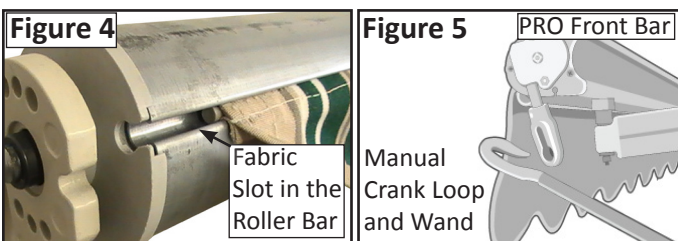

22. Remove the new Fabric from its packaging. Orient it the same way as explained in **Step 20**.

Note: The Fabric must be inserted into the Roller Bar and Front Bar Slots at the same time. You might have to do so in small steps, alternating from one Bar to the other.

CAUTION: To Prevent Damage to the Fabric, Have Your Helper Direct the Fabric into the Slot, While You Slowly Pull the Fabric Through the Slot, to the Other End.

23. With your helper, carefully insert the Fabric into the slots on the Roller Bar and Front Bar. You might have to hold the Front Bar steady while doing so. Repeat for the Valance.

24. Center the Fabric on the Roller Bar and the Front Bar.

25. While keeping the Fabric reasonably stretched on the Roller Bar, use the Manual Crank Wand to slowly roll the Fabric onto the Roller Bar, until both arms start to close.

26. Reinstall the End Plate on the Front Bar with the three Phillips screws (see **Figure 7**), and roll the Weather Breaker Front Panel completely up.

27. Reinstall the Hood End Plate if removed.

28. Check that the Remote Transmitter or Wall Switch is still in the neutral position (press the MY button), then plug the power cord back into the outlet.

29. Test the Awning and Weather Breaker Panel for proper operation.

Note: If you need to adjust motor stops, refer to the enclosed instructions on how to reset the motor stops. See the next section for identification of your specific Motorized Awning Motor.

How to Identify Your Specific Type of Motor for Resetting Motor Stops

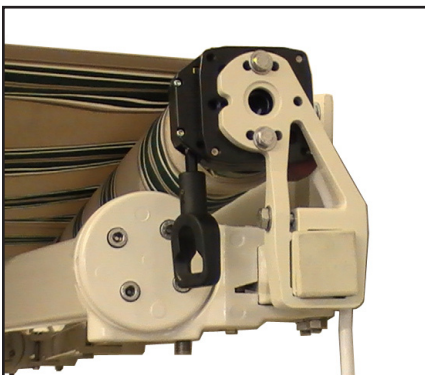

RTS Type Motor

Shipped with Awnings prior to 2012.

Identified by Black Square Motor Plate on End.

Set the Open and Close Stop Positions with Manual Push Buttons on the Motor.

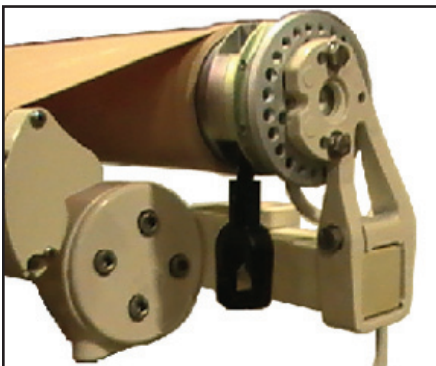

Sunea Type Motor

Shipped with Awnings beginning in 2012.

Identified by Silver Round Motor Plate on End.

Set the Open and Close Stop Positions with the Remote Transmitter and Electronic Controls inside the Motor.

For Sunea Motor Only (see bottom of page 3 for motor identification)

Resetting Remote Communication and Reprogramming the Motor

This procedure will completely reset the communication between the Remote Transmitter and Motor, as well as erase and reprogram the **Open** and **Closed** stop position settings of the Motor.

This procedure programs the Awning Motor to accept commands from one primary Remote Transmitter.

This procedure overwrites the factory set **Open** and **Closed** positions with new **Open** and **Closed** positions.

Note: To **ONLY** change the **Open** and **Close** preset positions, follow the basic procedure in Appendix B.

Tools needed: A pen or similar pointing device is needed to press and hold the Programming Button.

WARNING: ALL STEPS MUST BE FOLLOWED EXACTLY AND COMPLETELY.



PREPARE MOTOR - Read these instructions FIRST, completely and thoroughly

1. Set the Remote Transmitter to Channel 1.
2. Press and Hold the **my** button; the red LED light should blink for at least 5 seconds.
3. Disconnect Power for two (2) full seconds.
4. Connect Power for ten (10) full seconds.
5. Disconnect Power for two (2) full seconds.
6. Connect Power. The Awning should move, then stop on its own.
7. Press and hold the **Programming** button for ten (10) seconds, watching for two (2) separate jogs back and forth, several seconds apart.

Note: A single jog is defined as a quick two-direction movement of the motor.

8. Press and Hold the **CLOSE** and **OPEN** buttons together, release when the Awning jogs.
Note: The Awning now moves **ONLY** while holding down the **CLOSE** or **OPEN** button.

SET PROPER DIRECTION OF MOTOR ROTATION

9. Press the **OPEN** button to check the direction of the motor.
The fabric should **roll from the top** of the Roller Bar, opening the Awning.
10. If the direction is incorrect, change direction by holding the **my** button until the motor jogs.
Press the **OPEN** button again to check for the correct direction of the motor rotation.



SET THE CLOSED AND OPEN POSITIONS

11. Move the Awning to the desired **Closed** position.
12. Press and Hold the **my** and **OPEN** buttons together; release when the Awning begins to **Open**.
13. Press the **my** button to **Stop** the Awning at the desired **Open** setting.
14. Make desired adjustments to the **Open** position.
15. Press and Hold the **my** and **CLOSE** buttons simultaneously; release them when the Awning begins to **Close**. **Let the Awning stop on its own** at the **Closed** position set in step 11.
16. Press and Hold the **my** button; release when the Awning jogs. This step stores the new **Open** and **Close** positions.

Note: If steps 8 - 15 fail, unplug the Awning, plug it back in, then begin again from step 8.

FINALIZE PROGRAMMING OF MOTOR

17. Press and Hold the **Programming** button; wait for a jog. This completes the procedure.
Note: The Awning now operates with a touch and release of the **OPEN** or **CLOSE** button.
18. Test the Awning for correct one-touch operation, using the **OPEN** and **CLOSE** buttons.

To Add or Delete a Control Device (Transmitter)

To **ADD** an additional Control Device (such as another Remote or Channel or Wall Switch);

- Press the Programming button on the back of the Transmitter that was supplied with the Awning until the motor “jogs.”
- On the additional Control Device, press the Programming button until the motor “jogs,” then release.

To **DELETE** a Control Device, repeat the two steps listed above and the additional Control Device is removed.

For RTS Motor Only (see bottom of page 3 for motor identification)

RESETTING THE LIMIT PUSH BUTTONS OF THE SUNSETTER MOTOR

Awnings with Motors installed on the Right as you face the house

Note: Visual Guide available on Installation DVD and on the Owner's Corner.

1. If the motor on your SunSetter Awning is mounted on the right, as you face the house, complete Steps 1 thru 13. If motor on your SunSetter Awning is mounted on the left, as you face the house, complete Steps 14 thru 24 on page 18.

Note: If your awning has a Hood installed, you may need to remove the right end plate from the Hood to gain access to the motor push buttons.

2. Press the Neutral/Stop button on the remote.
3. Unplug the power cord from the electrical outlet on the wall.
4. From a stepladder locate the limit push buttons on the motor. These push buttons will be on top of the motor housing under a black plastic protective cap – see Fig 13.
5. Grasp the black protective cap and lift it up. You will notice one yellow button and one white button inside a recessed area. These are the limit push buttons for the **OPEN** and **CLOSE** positions for the motorized awning.
6. Clear the Factory Settings by separately pressing both buttons (white and yellow) until they are both 'IN' or at their lowest point inside the recessed area of the motor housing –see figure 13. You should practice this a few times to understand this process.

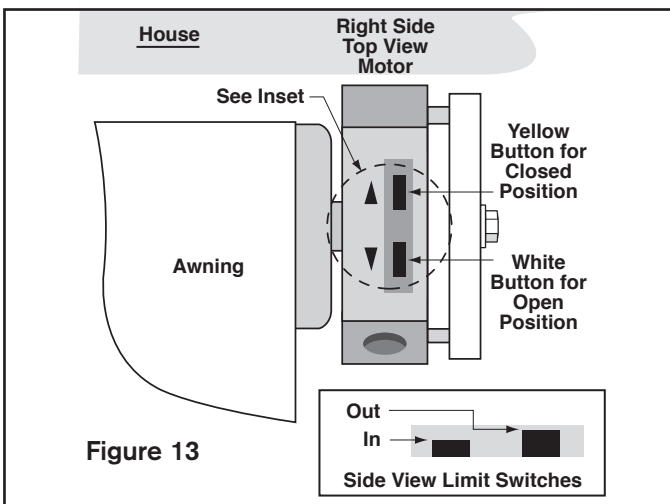

7. Manually crank the awning open to the point where both lateral arms 'lock' into the fully extended position. The fabric will also be at its tightest point.

NOTE: The fabric should be rolling over the top of the roller bar (figure 14a), not underneath (figure 14b). If the fabric is rolling from the bottom of the roller bar, continue unrolling the fabric until it rolls over the top of the roller bar. Then roll up the fabric until both lateral arms 'lock' and the fabric becomes tight.

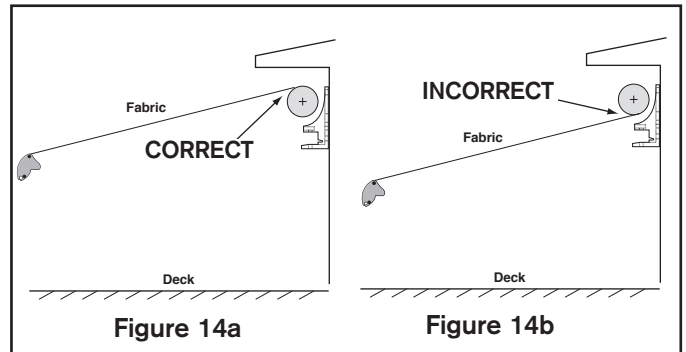

8. Depress the white button so that it is in the 'OUT' position (or closer to the top of the recessed area on the motor housing). Now the **OPEN** position stop is set.

9. Manually roll the awning up until it is almost completely closed. The area to watch is where the front bar almost touches the round side of the arm clamp – see figure 15. Leave about 1/2" gap between the front bar and the round side of the arm clamp.

10. Depress the yellow button so that it is in the 'OUT' position (or closer to the top of the recessed area on the motor housing). Now the **CLOSE** position stop is set.

11. Replace the black protective cap on the motor housing. Be careful that the cap will not accidentally depress one of the limit push buttons underneath.

12. Plug the power cord back into the electrical outlet on the wall.

13. Test the awning for proper operation. Reinstall Hood end plate if removed.

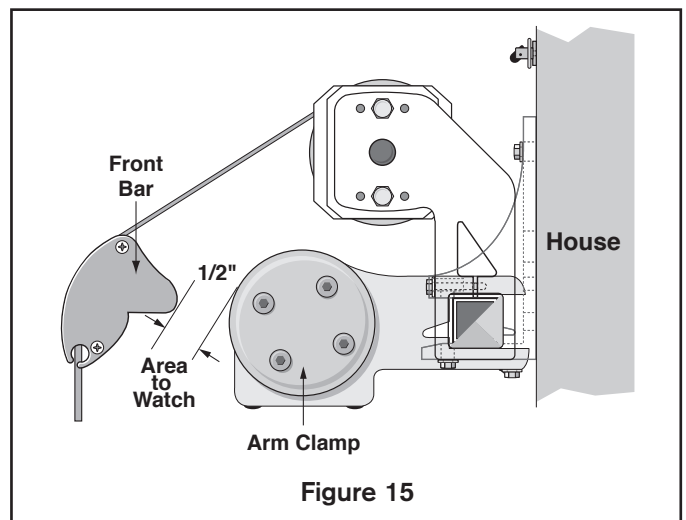

Awnings with Motors installed on the Left as you face the house

14. Press the Neutral/Stop button on the remote.

15. Unplug the power cord from the electrical outlet on the wall.

Note: Black protective cap for use with Right Motor Installations Only.

16. From a stepladder locate the limit push buttons on the motor. These push buttons will be on the underside of the motor housing. – see Figure 16.

17. You will notice one yellow button and one white button inside a recessed area. These are the limit push buttons for the **OPEN** and **CLOSE** positions for the motorized awning.

18. Clear the Factory Settings by separately pressing both buttons (white and yellow) until they are both 'IN' or at their lowest point inside the recessed area of the motor housing –see figure 16. You should practice this a few times to understand this process.

19. Manually crank the awning open to the point where both lateral arms 'lock' into the fully extended position. The fabric will also be at its tightest point.

NOTE: The fabric should be rolling over the top of the roller bar (figure 14a), not underneath (figure 14b). If the fabric is rolling from the bottom of the roller bar, continue unrolling the fabric until it rolls over the top of the roller bar. Then roll up the fabric until both lateral arms 'lock' and the fabric becomes tight.

20. Depress the yellow button so that it is in the 'OUT' position (or closer to the top of the recessed area on the motor housing). Now the **OPEN** position stop is set.

21. Manually roll the awning up until it is almost completely closed. The area to watch is where the front bar almost touches the round side of the arm clamp – see figure 17. Leave about 1/2" gap between the front bar and the round side of the arm clamp.

22. Depress the white button so that it is in the 'OUT' position (or closer to the top of the recessed area on the motor housing). Now the **CLOSE** position stop is set.

23. Plug the power cord back into the electrical outlet on the wall.

24. Test the awning for proper operation.

